

Flight and Wind Tunnel Testing

Robert Stengel, Aircraft Flight Dynamics
MAE 331, 2018

Learning Objectives

- How to estimate the aerodynamics of the full-scale airplane
- Review characteristics of large- and small-scale wind tunnels
- Appreciate the concept of airplane flying (i.e., handling) qualities
- Be aware of Princeton's flight research heritage

Reading:
Airplane Stability and Control
Chapter 3

Wikipedia: Flight Testing, Wind Tunnel Testing



Copyright 2018 by Robert Stengel. All rights reserved. For educational use only.
<http://www.princeton.edu/~stengel/MAE331.html>
<http://www.princeton.edu/~stengel/FlightDynamics.html>

1

NACA Free Flight Wind Tunnels

- Test section angle and airspeed adjusted to gliding flight path angle and airspeed

5-ft Free Flight Wind Tunnel

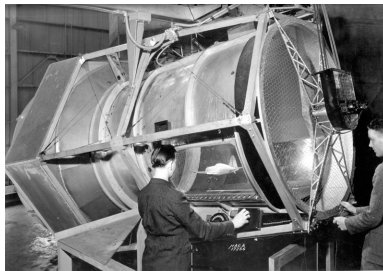

12-ft Free Flight Wind Tunnel

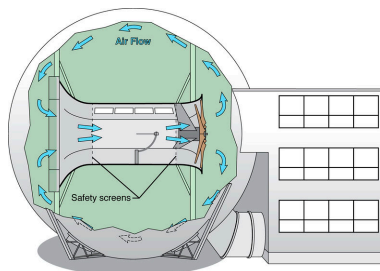

http://crgis.ndc.nasa.gov/historic/12-Foot_Low_Speed_Tunnel

2

Recirculating (Closed-Return) Wind Tunnels

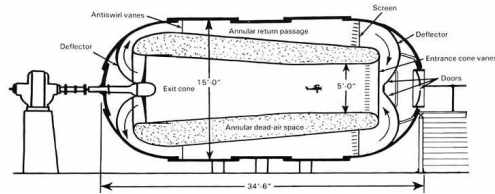

3

Full-Scale Wind Tunnels

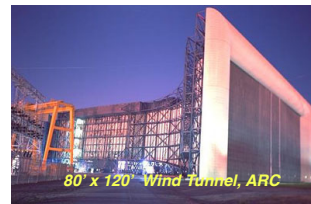

Blended Wing-Body Model in Free Flight
<http://www.youtube.com/watch?v=B7zMKptajMQ>

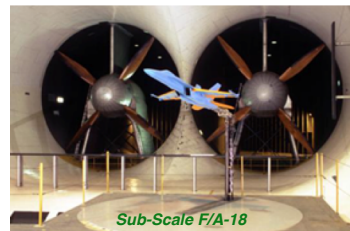

4

Interpreting Wind Tunnel Data

- **Wall corrections**, uniformity of the flow, turbulence, flow recirculation, temperature, external winds (open circuit)
- **Open-throat tunnel** equilibrates pressure
- **Tunnel mounts and balances**: struts, wires, stings, magnetic support
- **Simulating power effects**, flow-through effects, aeroelastic deformation, surface distortions
- **Artifices** to improve reduced/full-scale correlation, e.g., boundary layer trips and vortex generators



Navion in the NASA Langley Research Center 30' x 60' Wind Tunnel

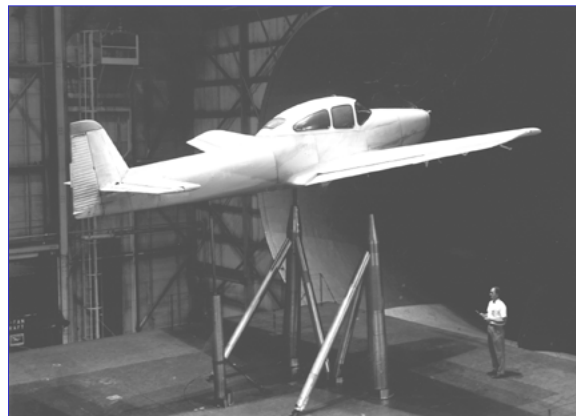

6

Wind Tunnel Force and Moment Data

Three-Strut Mount



Single-Strut Mount

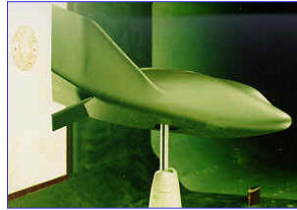

Sting Balance

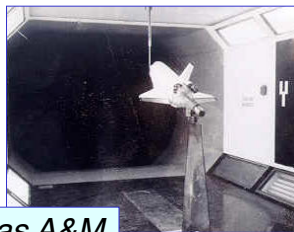

Texas A&M

*High-Angle-of-Attack
Sting Balance*



7

Flying (or Handling) Qualities

- **Stability and controllability perceived by the pilot**
- 1919 flight tests of *Curtiss JN-4H Jenny* at *NACA Langley Laboratory* by Warner, Norton, and Allen
 - Elevator angle and stick force for equilibrium flight
 - Correlation of elevator angle and airspeed with stability
 - Correlation of elevator angle and airspeed with wind tunnel tests of pitch moment

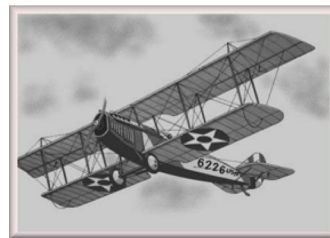

8

Early Flight Testing Instrumentation

- Flight recording instruments: drum/strip charts, inked needles, film, galvanometers connected to air vanes, pressure sensors, clocks

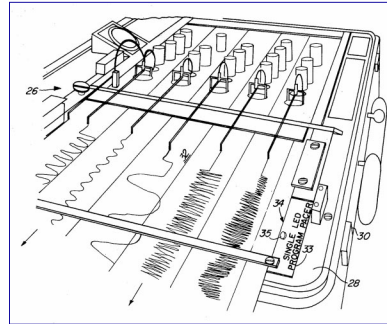

9

Hundreds/Thousands of Measurements Made in Modern Flight Testing

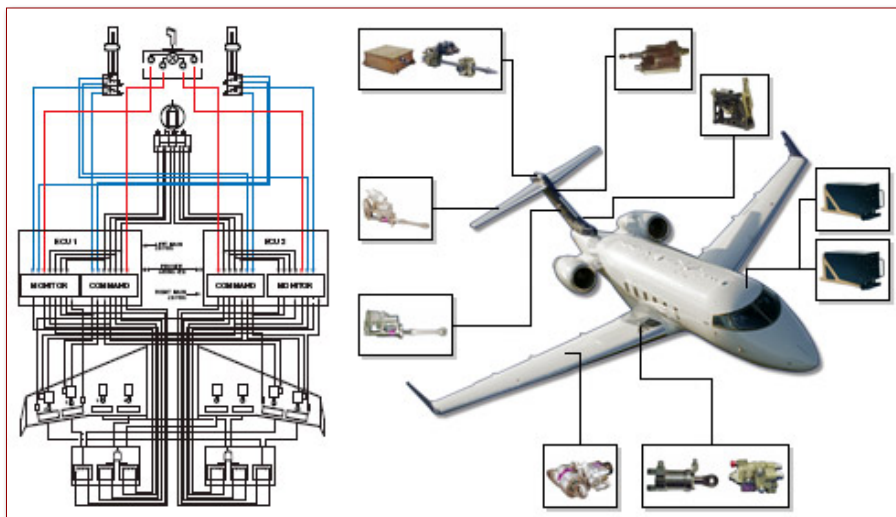

10

Flight Testing Instrumentation

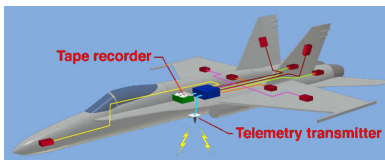
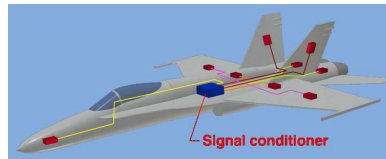
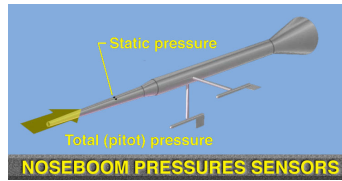
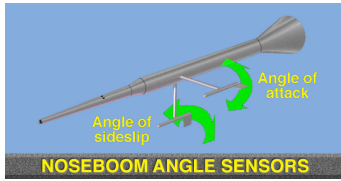

11

Air Data System

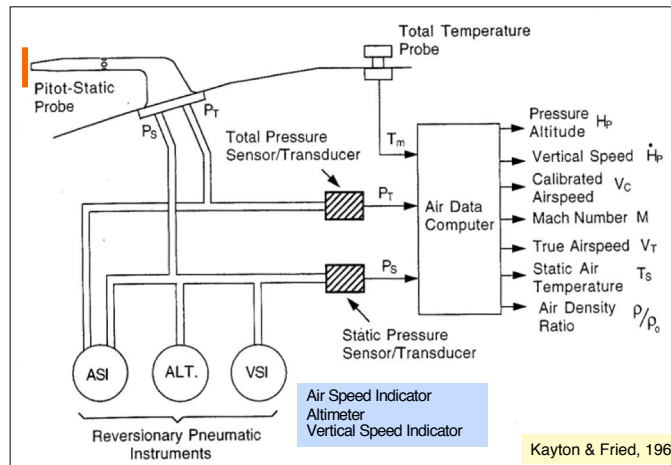

- **Subsonic speed:** no shock wave ahead of pitot tube
- **Supersonic speed:** normal shock wave ahead of pitot tube₁₂

Air Data Probes

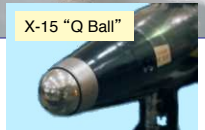
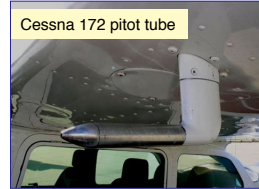
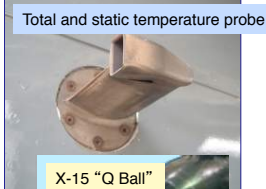
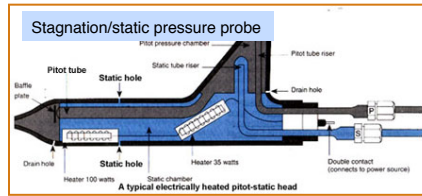

13

Flight Testing Instrumentation

- Air data measurement far from disturbing effects of the aircraft

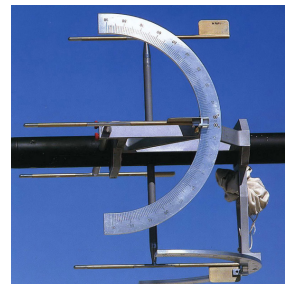

$$\mathbf{z} = \begin{bmatrix} P_{stagnation} & T_{stagnation} \\ P_{static} & T_{static} \\ \alpha_B \\ \beta_B \end{bmatrix} = \begin{bmatrix} \text{Stagnation pressure and temperature} \\ \text{Static pressure and temperature} \\ \text{Angle of attack} \\ \text{Sideslip angle} \end{bmatrix}$$

14

Trailing Tail Cones for Accurate Static Pressure Measurement

- Air data measurement far from disturbing effects of the aircraft



15

Dynamic and Impact Pressure

$$\bar{q} \triangleq \rho V^2 / 2 : \text{Dynamic pressure}$$

$$q_c = P_{total} - P_{static} : \text{Impact pressure}$$

- Dynamic pressure also can be expressed in terms of Mach number and static (ambient) pressure

$$P_{stat}(z) = \rho_{amb}(z) RT(z) \quad [\text{Ideal gas law, } R = 287.05 \text{ J/kg-}^\circ\text{K}]$$

$$a(z) = \sqrt{\gamma RT(z)} \quad [\text{Speed of sound, } T = \text{absolute temperature, } ^\circ\text{K, } \gamma = 1.4]$$

$$M = V/a \quad [\text{Mach number}]$$

Substituting

$$\bar{q} \triangleq \rho_{amb}(z) V^2 / 2 = \frac{\gamma}{2} P_{stat}(z) M^2$$

- In incompressible flow, dynamic pressure = impact pressure

16

Compressibility Effects on Impact Pressure

- In subsonic, isentropic compressible flow

$$\frac{p_{total}(z)}{p_{static}(z)} = \left(1 + \frac{\gamma - 1}{2} M^2\right)^{\gamma/(\gamma - 1)}$$

- Impact pressure is

$$q_c \triangleq [p_{total}(z) - p_{static}(z)] = p_{static}(z) \left[\left(1 + 0.2 M^2\right)^{3.5} - 1 \right]$$

- In supersonic, isentropic compressible flow, impact pressure is

$$q_c = p_{static}(z) \left\{ \frac{1 + \gamma}{2} M^2 \left[\frac{(\gamma + 1)^2}{4\gamma - \frac{2(\gamma - 1)}{M^2}} \right]^{1/(\gamma - 1)} - 1 \right\}$$

17

First Flying Qualities Specification

- **First flying qualities specification: 1935**
 - Edward Warner. *Douglas DC-4E* transport (one prototype, never produced)
 - Interviews with pilots and engineers
 - Why three short vertical stabilizers?
 - Tricycle landing gear



18

Flying Qualities Research at NACA

- **Hartley Soulé and Floyd Thompson (late 1930s)**
 - Long- and short-period motions
 - Time to reach specified bank angle
 - Period and damping of oscillations
 - Correlation with pilot opinion
- **Robert Gilruth (1941-3)**
 - Parametric regions and boundaries
 - Multi-aircraft criteria
 - Control deflection, stick force, and normal load factor
 - Roll helix angle
 - Lateral control power



19

Gilruth Roll-Rate Criterion [$pb/2V$]

- **Helix angle formed by rotating wing tips, $pb/2V$**
 - Roll rate, p , rad/s
 - Wing semi-span, $b/2$, m
 - Velocity, V , m/s
- **Robert Gilruth criterion**
 - $pb/2V > 0.07$ rad

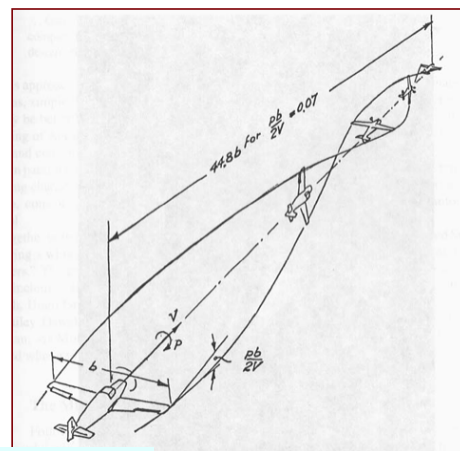

NACA TR-715, 1941

20

Aerial Refueling

- Difficult flying task
- High potential for PIO
- Alternative designs
 - Rigid boom (USAF)
 - Probe and drogue (USN)



23

Formation Flying

- Coordination and precision
- Potential aerodynamic interference
- *US Navy Blue Angels (F/A-18)*

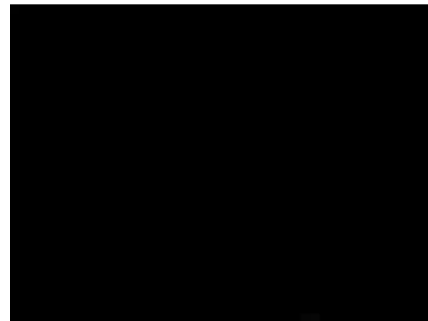

24

Aircraft That Simulate Other Aircraft

- Closed-loop control
- Variable-stability research aircraft, e.g., *TIFS*, *AFTI F-16*, *NT-33A*, and *Princeton Variable-Response Research Aircraft (Navion)*



25

Effect of Equivalent Time Delay on Cooper-Harper Rating

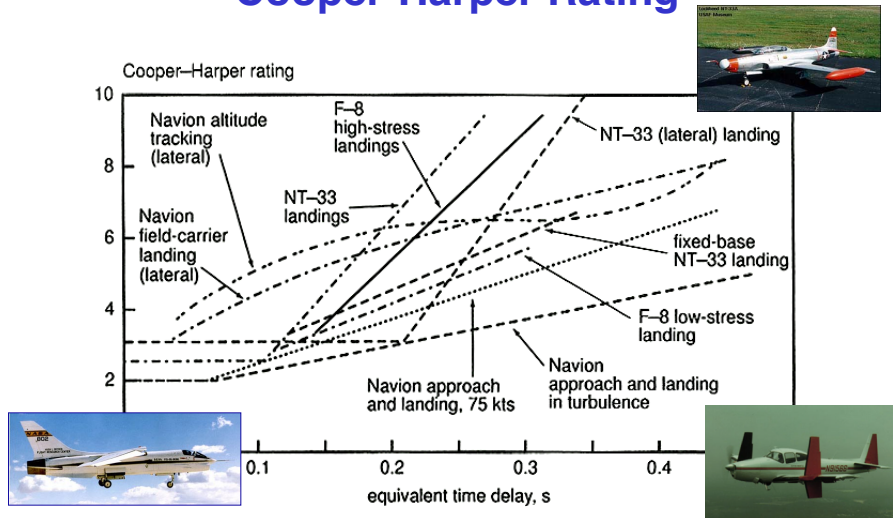

Rate of degradation of Cooper-Harper pilot ratings increases with difficulty of task

26



Princeton University's Flight Research Laboratory (1943-1983)

Robert Stengel, Aircraft Flight Dynamics, MAE 331, 2014



- Forrester Campus
- 3,000-ft dedicated runway

Copyright 2014 by Robert Stengel. All rights reserved. For educational use only.
<http://www.princeton.edu/~stengel/MAE331.html>
<http://www.princeton.edu/~stengel/FlightDynamics.html>

27

Helicopters and Flying Saucers



- Piasecki HUP-1 helicopter
- Hiller H-23 helicopter
- Princeton Air Scooter
- Hiller VZ-1 Flying Platform
- Princeton 20-ft Ground Effect Machine

28

Short-Takeoff-and-Landing, Inflatable Plane, and the Princeton Sailwing



- *Helio Courier*
- *Goodyear InflatoPlane*
- *Princeton Sailwing*

<https://www.youtube.com/watch?v=HAqcBRMI-Vs>



29

Variable-Response Research Aircraft (Modified North American Navion A)

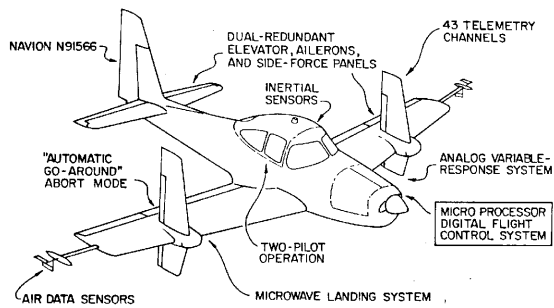

30

Avionics Research Aircraft (Modified *Ryan Navion A*)



Lockheed LASA-60 Utility Aircraft



Schweizer 2-32 Sailplane (“Cibola”)



Steve Sliwa, '77, landing on Forrestal Campus runway, currently CEO, In Situ, Inc.

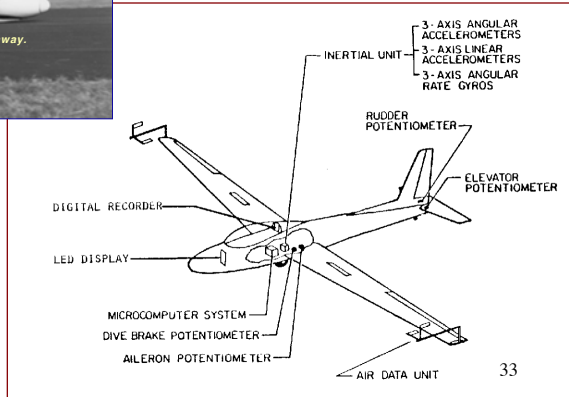

Propeller-Driven Personal Aircraft

- Single reciprocating engine, mechanical controls, fixed or retracting gear, high price
- **Cirrus SR-20/22** has a recovery parachute
 - Used 95 times through 2018, saved 165 lives, 1 fatality
 - Other fatal accidents: 133 with 258 fatalities



Cessna 172



Mooney M20



Beech Bonanza A36



Cirrus SR20/22



Piper Malibu



34

Business Jets

Twin turbojet/fan engines



North American Sabreliner



Learjet 24



Cessna Citation I



Gulfstream II

35

Aviation Safety *(various sources)*

- **Accident rates, 2011**
 - **General aviation**
 - 7 accidents/100,000 flight-hours
 - 1.2-2.2 fatalities/100,000 flight-hours
 - **Commercial aviation**
 - 0.16 accidents/100,000 flight-hours
 - 0.4 fatalities/100,000 flight-hours
 - **Automobiles**
 - 0.06-0.2 fatalities/100,000 driving hours

http://home.iwichita.com/rh1/eddy/Safe_Airplane_NOT.htm

http://en.wikipedia.org/wiki/Aviation_safety

<http://www.flyingmag.com/blogs/going-direct/crisis-flight-training-42>

<http://www.princeton.edu/~stengel/TimeToReinvent.pdf>

https://www.nts.gov/data/aviation_stats.html

http://www.nytimes.com/2014/07/17/opinion/The-Dangers-of-Private-Planes.html?_r=0

36

Supplementary Material

37

Air Data Instruments ("Steam Gauges")

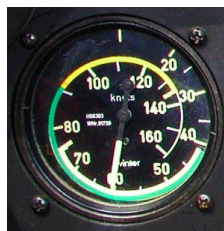

Calibrated Airspeed Indicator



Altimeter

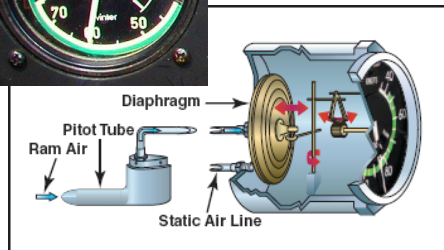

$1 \text{ knot} = 1 \text{ nm} / \text{hr}$
 $= 1.151 \text{ st. mi.} / \text{hr} = 1.852 \text{ km} / \text{hr}$

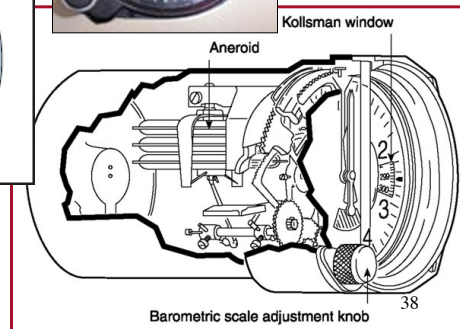

38

Modern Aircraft Cockpit Panels

Cirrus SR-22 Panel



Boeing 777 "Glass Cockpit"



Air Data Computation for Subsonic Aircraft

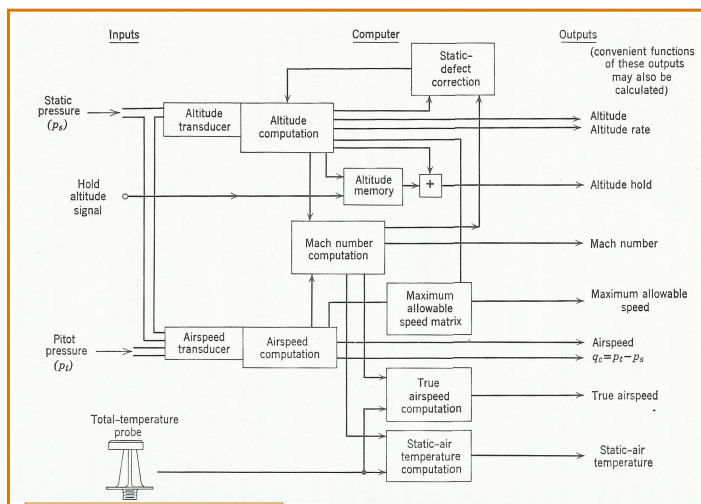

Kayton & Fried, 1969

Air Data Computation for Supersonic Aircraft

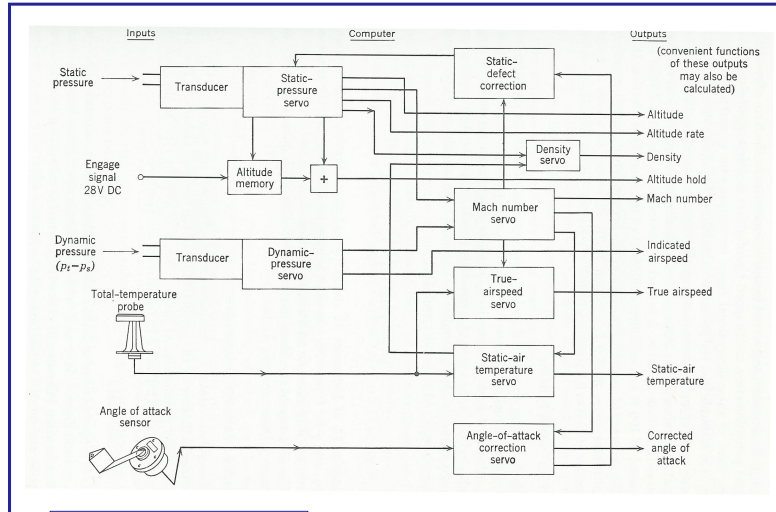

Kayton & Fried, 1969

41

Apple iPhone Used for On-Board Data Processing and Recording

Jillian Alfred, Clayton Flanders, Brendan Mahon
Princeton Senior Project, 2010

iPhone Installation

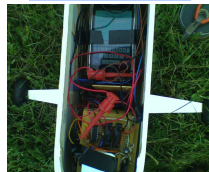

Hobbico NexSTAR



System Components

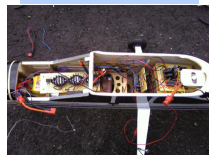

Pitot Tube Placement

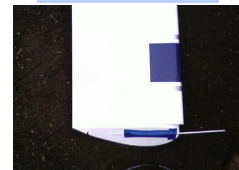

42

Autonomous UAV Control in a Simulated Air Traffic Control System

Atray Dixit, Jaiye Falusi, Samuel Kim, Gabriel Savit
Princeton Senior Project, 2012

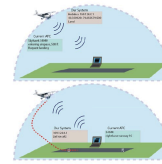

Overview

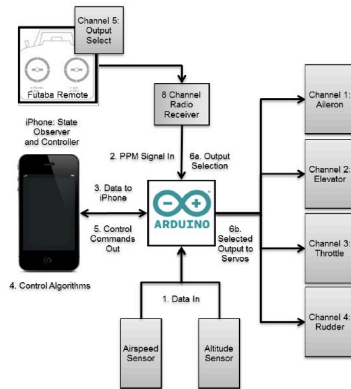

System Hardware

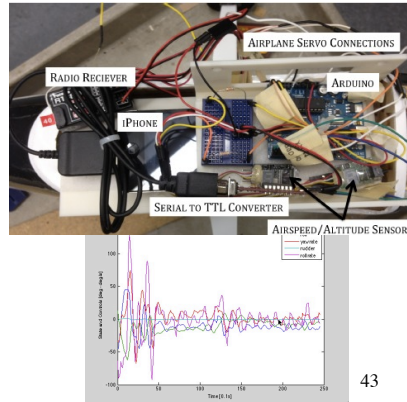

43

MIL-F-8785C Superseded by MIL-STD-1797

- Handbook for guidance rather than a requirement
- Body of report is a form, with numbers to be filled in for each new aircraft, e.g.,

4.8.4.2.1 Stall approach. The aircraft shall exhibit the following characteristics in the stall approach:

- The onset of warning of stall approach (4.8.4.1) shall occur within the following speed range for 1-g stalls: _____, and within the following range (or percentage) of lift for accelerated stalls: _____, but not within the Operational Flight Envelope.
- An increase in intensity of the warning with further increase in angle of attack shall be sufficiently marked to be noted by the pilot. The warning shall continue until the angle of attack is reduced to a value less than that for warning onset. Prior to the stall, uncommanded oscillations shall not _____.
- At all angles of attack up to the stall, the cockpit controls shall remain effective in their normal sense, and small control inputs shall not result in departure from controlled flight.
- Stall warning shall be easily perceptible and shall consist of _____.

- Useful reference data contained in Appendix A (~700 pages)

44

Flight Testing for Certification in Other Agencies

- **Federal Aviation Administration Airworthiness Standards**
 - Part 23: GA
 - Part 25: Transports
- **UK Civil Aviation Authority**
- **European Aviation Safety Agency**
- **Transport Canada**

45

UAV Handling Qualities

- ***UAV Handling Qualities.....You Must Be Joking,***
Warren Williams, 2003
 - UAV missions are diverse and complex
 - All UAVs must have sophisticated closed-loop flight control systems
 - Cockpit is on the ground; significant time delays
 - Launch and recovery different from takeoff and landing
- **Suggestion: Follow the form of MIL-F-8785C, FAR Part 23, etc., but adapt to differences between manned and unmanned systems**

46

Even the Best Specs Cannot Prevent Pilot Error



TAROM Flight 381 (A310 "Muntenia")
<http://www.youtube.com/watch?v=VqmrRFeYzBI>

On **September 24, 1994**, TAROM Airbus A310 on approach went into a sudden and uncommanded nose-up position and stalled

Cause: overshoot of flap placard speed during approach, incorrectly commanded by captain, caused a mode transition.

- Auto-throttles increased power
- Trim went full nose-up as a result
- Commanding the nose-down elevator could not counteract effect of stabilizer nose-up trim

The plane landed safely on second approach

47

Pilot Error, or Aircraft Maintenance, or Both?

TAROM Flight 371 (A310 "Muntenia")
http://www.youtube.com/watch?v=RZ_RkHi7Pao

TAROM Airbus A310 crashed shortly after it took off near Balotești in Romania on **31 March 1995**.

Two main reasons:

- **the throttle of the starboard engine jammed, remaining in takeoff thrust, while the other engine reduced slowly to idle, creating an asymmetrical thrust condition** that ultimately caused the aircraft to roll over and crash.
- **the crew failed to respond to the thrust asymmetry.**

60 fatalities

48

The Mysterious Disappearance of Air France Flight 447 (Airbus A330-200)

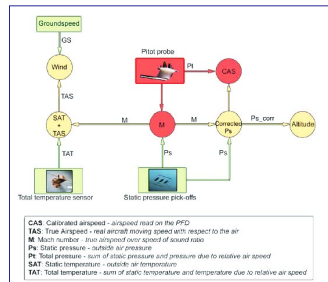

Suspected Failure of Thales Heated Pitot Probe

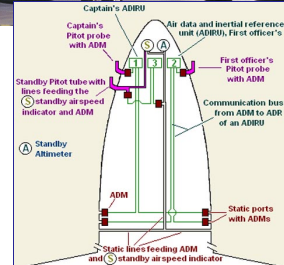

"Visual examination showed that the airplane was not destroyed in flight; it appears to have struck the surface of the sea in level flight with high vertical acceleration."

BEA Interim Reports, 7/2/2009 & 11/30/2009
<http://www.bea.aero/en/enquetes/flight.af.447/flight.af.447.php>

http://en.wikipedia.org/wiki/AF_447